

REV.
C

AS4340

RATIONALE

CORRECTED END 2 TO STYLE "E" IN FIGURE 1, UPDATED NOTE /4/ TO DELETE "PRI" STATEMENT, AND CORRECT THE NADCAP SCOPE TO AC7112, AC7112/2.

SAE Technical Standards Board Rules provide that: "This report is published by SAE to advance the state of technical and engineering sciences. The use of this report is entirely voluntary, and its applicability and suitability for any particular use, including any patent infringement arising therefrom, is the sole responsibility of the user." SAE reviews each technical report at least every five years at which time it may be revised, reaffirmed, stabilized, or cancelled. SAE invites your written comments and suggestions.

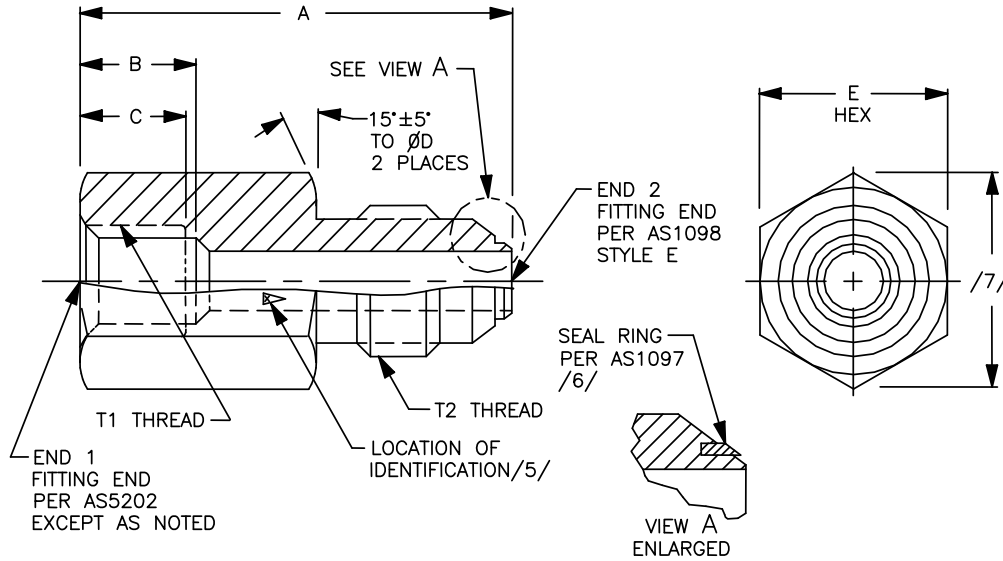
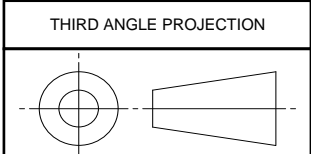

FIGURE 1 - FITTING, BUSHING, SCREW THREAD REDUCER

TABLE 1 - DIMENSIONS AND WEIGHTS

BASIC NUMBER AS4340 /15/ SIZE CODE	T1 THREAD (NOMINAL TUBE SIZE) PER AS8879 CLASS 3A END 1	T2 THREAD (NOMINAL TUBE SIZE) PER AS8879 CLASS 3A END 2	A					D		LB/EA APPROX REF ALUM	LB/EA APPROX REF CRES
			+0.000 -0.032	B	C	±.010	E				
0408	.250 .4375-20UNJF	.500 .7500-16UNJF	1.016	.672	.568	.980	.990-1.003	.0288	.0799		
0612	.375 .5625-18UNJF	.750 1.0625-12UNJ	1.266	.630	.470	1.353	1.363-1.380	.0676	.187		
0812	.500 .7500-16UNJF	.750 1.0625-12UNJ	1.641	.750	.562	1.353	1.363-1.380	.125	.346		
0816	.500 .7500-16UNJF	1.000 1.3125-12UNJ	1.688	.750	.562	1.603	1.613-1.630	.179	.497		
1216	.750 1.0625-12UNJ	1.000 1.3125-12UNJ	1.922	.940	.688	1.603	1.613-1.630	.198	.550		

SAE values your input. To provide feedback on this Technical Report, please visit <http://www.sae.org/technical/standards/AS4340C>



CUSTODIAN: G-3/G-3B

PROCUREMENT SPECIFICATION: /4/ KSC-F-124



AEROSPACE STANDARD

FITTING, BUSHING,
SCREW THREAD REDUCER,
FOR SEAL RING

AS4340
SHEET 1 OF 3

REV.
C